

# HELISTAR PLB-

中空軸型磁粉制動器(0.3~40kgfm)

Hollow shaft type powder brake

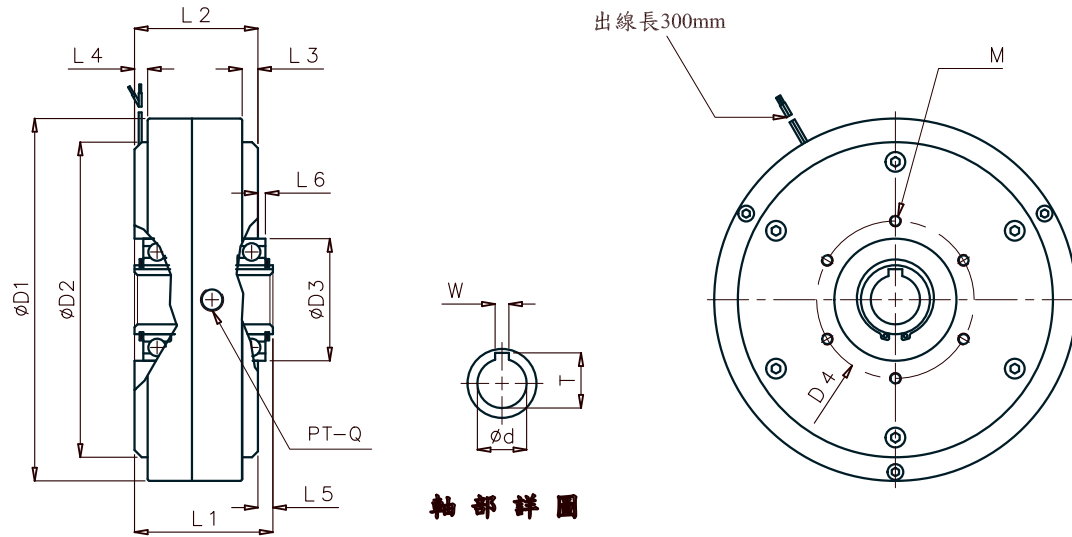

型式	L1	L2	L3	L4	L5	L6	D1	D2	D3	D4	Q	M		軸部		
												徑	深	d(H7)	W(F8)	T <sub>(+0.3)</sub> <sup>0</sup>
PLB-012	70	50		5	10	7	134	114	62	125/110	1/8	3-M6/M4	10/6	25	8	28.3
PLB-025	67	60	8	7.5	7	4	152	125.5	62	80	1/8	6-M6	10	25	8	28.3
PLB-050	72	63	8	7	8.6	4.8	184	160	68	92	1/8	6-M6	10	30	8	33.3
PLB-100	89	80	12	12	9	5	219	190	90	120	1/4	6-M8	15	35	10	38.3
PLB-200	129	117.8	25	25	11	9	278	250	125	150	3/8	6-M10	15	45	14	48.8
PLB-400	145	134	27	27	11	6	327	290	125	160	3/8	6-M10	20	50	14	53.8

\*空轉轉矩為額定轉矩的3%以下\*

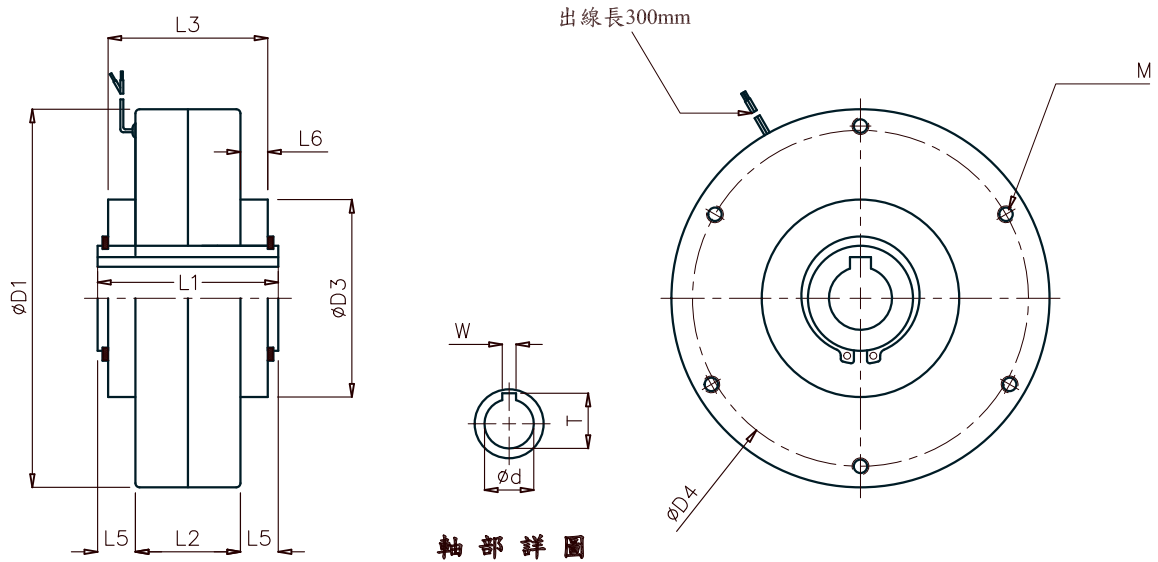

型式	L1	L2	L3	L4	L5	L6	D1	D2	D3	D4	Q	M		軸部		
												徑	深	d(H7)	W(F8)	T <sub>(+0.3)</sub> <sup>0</sup>
PLB-0.3	43	25	38		9	6.5	90		47	80		3-M4	6	15	5	17.3
PLB-0.6	49	30	43		9.5	6.5	105		55	97		3-M4/M5	6/10	20	6	22.8

\*空轉轉矩為額定轉矩的3%以下\*